

# XIBU senseFOAM - ORDER INFORMATION

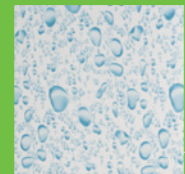

Decorative options  
for transparent centre  
section (light)



**[water]**  
Art.Nr. 110201058



**[steel]**  
Art.Nr. 110201053

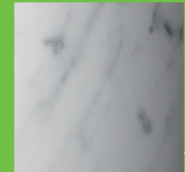

**[ceramic]**  
Art.Nr. 110201055



**[cotton]**  
Art.Nr. 10201056

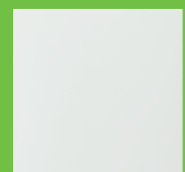

**[white]**  
Art.Nr. 110201050



Decorative options  
for transparent centre  
section (dark)



**[wood]**  
Art.Nr. 110201060

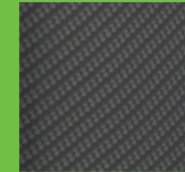

**[carbon]**  
Art.Nr. 110201057

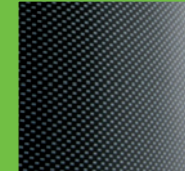

**[tech]**  
Art.Nr. 110201059



**[marble]**  
Art.Nr. 110201054

**XIBU senseFOAM** with foam generator for 0.6 kg HAGLEITNER foamSOAP in a patented vacuumBAG. Sensor-controlled dispensing with adjustable dispensing quantity, auto-stop, cleaning button, drip-free with reserve tank for up to 100 portions. Float-switch with electronic LED function display. Single-handed cover opening, lockable, available in nine decorative finishes\*. Housing made from anti-static, knock-proof ABS plastic.

\*high-grade plastic – decorative finishes

## Refills:

**septFOAMSOAP** 6 x 0.6 kg, Art. No. 110702603

For protective disinfection and cleaning of hands in a single step. Tested to EN 1499 at a dosage of 0.9 ml per application, listed according to DGHM/VAH and ÖGHMP quality standards. Dermatologically tested



**foamSOAP** 6 x 0.6 kg, Art. No. 110701503

Foamed, high-quality soap. Produces a velvety smooth foam. Particularly suitable for sensitive and dry skin. Dermatologically tested!

**systemBATTERY** type C, Art. No. 111201200, 2 pcs./pack

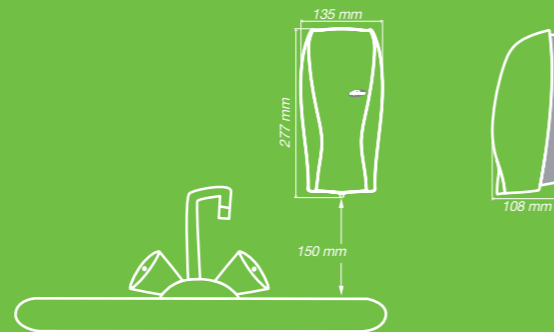

HAGLEITNER HYGIENE INTERNATIONAL GmbH  
Lunastrasse 5, 5700 Zell am See, Austria  
phone +43 (0) 6542 72896, fax +43 (0) 6542 74422

[www.hagleitner.com](http://www.hagleitner.com)



# senseFOAM

the new washroom generation

# XIBU

intelligent **balanced** unique



# XIBU senseFOAM - YOUR BENEFITS

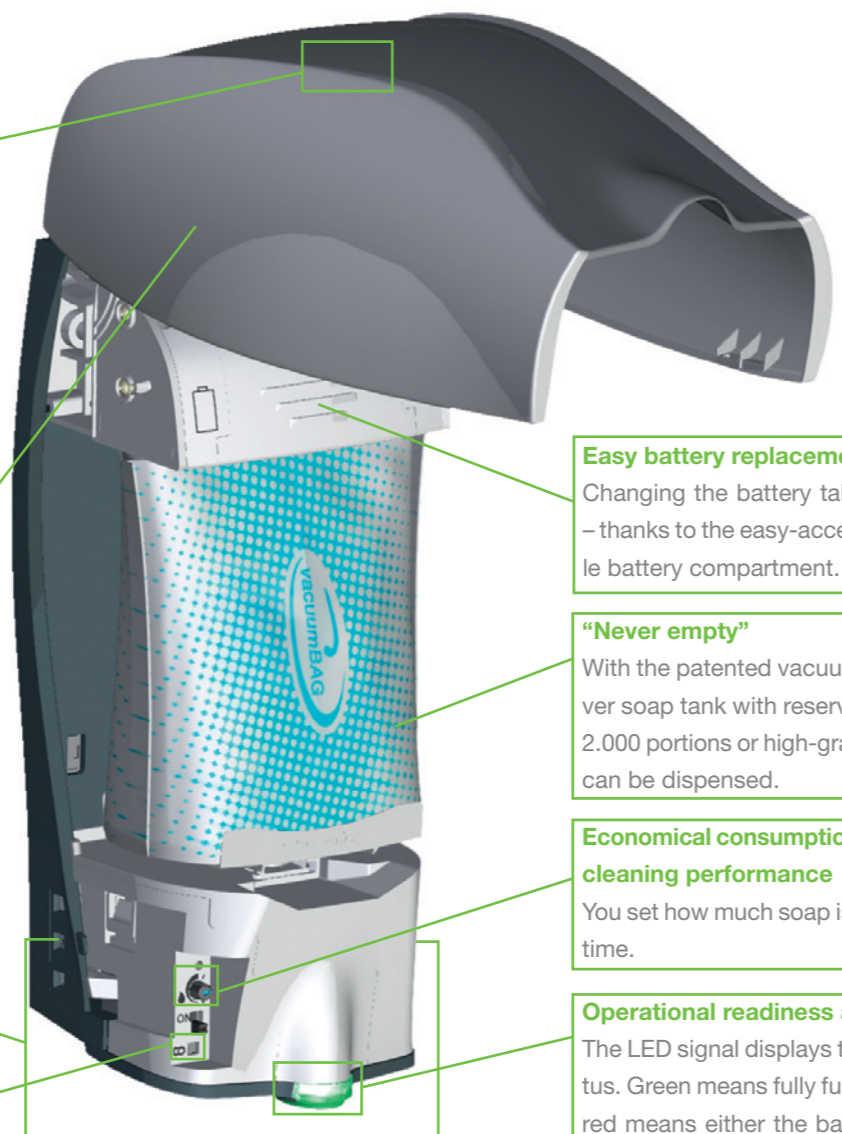

**Heavy-duty housing**  
The ABS plastic housing is resistant to knocks and scratches. The dispenser surface is easy to clean.

**Simple cover opening**  
You only need one hand to open the dispenser. The dispenser lid opens automatically and gently upwards.

**Flexible installation, anti-theft protection**  
Double-sided cover lock for flexible wall mounting. Your refill is protected against theft.

**Battery charge display**  
The LED light shows you how much charge is left in the battery.

**Standby mode**  
Activate the standby-mode with the cleaning button on the underside of the dispenser. This offers you uncomplicated cleaning underneath the dispenser at the press of button.

**Easy battery replacement**  
Changing the battery takes just seconds – thanks to the easy-access and removable battery compartment.

**“Never empty”**  
With the patented vacuumBAG and a clever soap tank with reserve capacity, up to 2.000 portions or high-grade foaming soap can be dispensed.

**Economical consumption with maximum cleaning performance**  
You set how much soap is dispensed each time.

**Operational readiness at a glance**  
The LED signal displays the operating status. Green means fully functioning. Green/red means either the battery or the soap is running low.

**Hands-free, convenient operation**  
The intelligent sensor technology recognises the presence of your hands and dispenses the soap automatically.

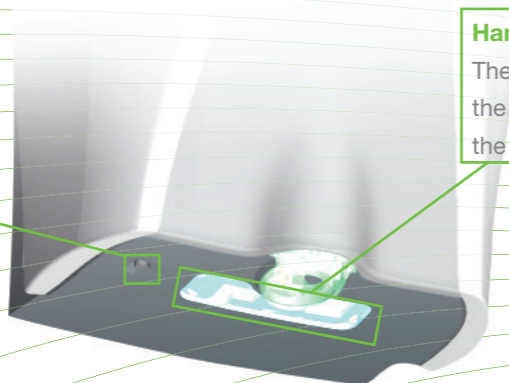

# THE HANDS-FREE FOAM SOAP DISPENSER

Experience the new generation of foam soap dispenser with **XIBU** senseFOAM. Economical consumption, service friendliness, unique design and hands-free operation – these are your benefits.

**intelligent**

The **XIBU** senseFOAM provides you with high-quality foam soap – without having to touch the dispenser. You choose whether you want to use pure foam soap on its own or with a disinfectant effect in a single operation. **That's your hygiene benefit!**

One glance at the senseFOAM dispenser and you'll see whether it is operationally ready – without having to open it. The LED light shows you when the battery or soap are running low. A clever reserve capacity system lets your dispenser carry on working in between refills. The system key lets you open the dispenser with one hand. **That makes servicing simple and saves time!**

**balanced**

Use our patented vacuumBAG as a refill. You adjust how much soap is dispensed each time. This innovative technology dispenses 660 to 2.000 portions, depending on the setting. **XIBU** senseFOAM combines **maximum cleaning with long-lasting performance.**

**unique**

Unique design and state-of-the-art functions go hand in hand – **XIBU**, the new washroom system from HAGLEITNER. Whether stylishly marbled ceramic or sporty high-tech carbon, the **XIBU** dispenser adapts to the **design of your washroom like a chameleon.** Choose your favourites from a total of nine decorative finishes.

**Innovative technology and flexible design**  
– that's what the XIBU washroom system stands for

